



US005803199A

United States Patent [19]

[11] Patent Number: **5,803,199**

Walter

[45] Date of Patent: **Sep. 8, 1998**

[54] **LIFT AUGMENTED GROUND EFFECT PLATFORM**

[75] Inventor: **William C. Walter**, Placerville, Calif.

[73] Assignee: **Hybricraft, Inc.**, Placerville, Calif.

[21] Appl. No.: **236,646**

[22] Filed: **May 2, 1994**

[51] Int. Cl.⁶ **B60V 1/11**

[52] U.S. Cl. **180/120; 180/117; 244/12.2**

[58] Field of Search 180/116, 117, 180/118, 120, 121, 126, 127-129; 244/73 B, 73 C, 12.2, 23 C; 114/67 A

[56] **References Cited**

U.S. PATENT DOCUMENTS

3,195,665	7/1965	Beardsley	180/116
3,276,723	10/1966	Miller et al.	244/12.2
3,489,374	1/1970	Morrom	244/12.2
3,532,179	10/1970	McCreary	180/117
3,747,726	7/1973	Walter	180/129
3,811,527	5/1974	Pout et al.	180/121
4,313,512	2/1982	Jutras	180/117
4,796,836	1/1989	Buchelt	244/12.2 X
5,203,521	4/1993	Day	244/12.2

FOREIGN PATENT DOCUMENTS

1276546	10/1961	France	180/117
---------	---------	--------	---------

OTHER PUBLICATIONS

McCafferty, Bob, "Skycar", *Popular Mechanics*, Jan. 1991, pp. 35-37.

"Tech Update," *Popular Mechanics*, Aug. 1991, p. 22.

"Aircraft Applications Fly With Cost/Performance," *Compounding Lines—RTP's Imagineering News Magazine*, Nov. 1993, pp. 1 & 3.

Swanborough, R.G., "Ryan VZ-3 Vertiplane," *Vertical Flight Aircraft Of The World*, Aero Publishers, 1964, p. 78.

Harding, Stephen, "Ryan VZ-3," *U.S. Army Aircraft Since 1947*, Specialty Press, 1990, p. 215.

Hardy, M. J., *Auro World Aircraft*, Patrick Stephens, Cambridge, England.

"Wingships," *Popular Mechanics*, May 1992, p. 38.

Van Horn, James, "NOTAR (no tail rotor) anti-torque system," McDonnell Douglas publication.

Richmond, Reed, "Flying Saucers You Can Park In Your Own Backyard," *Tomorrow's Technology Today!*, pp. 40-42, 119.

Astronautics, Nov. 1957, p. 67.

"PAR/WIG Project," Lockheed-Georgia Company.

Dore, Richard, "Floating On Air, Engineer Develops A Better Hovercraft," *The Daily Breeze*, Aug. 5, 1980.

Primary Examiner—Anne Marie Boehler
Attorney, Agent, or Firm—Fulwider Patton Lee & Utecht, LLP

[57] **ABSTRACT**

The lift augmented ground effect platform of the present invention is characterized by two pair of annular concentric air curtain nozzles and supercharge nozzles which direct respective jet streams downward and inward beneath the downwardly facing lifting surface of the platform. The concentric arrangement of the nozzles provides an inner or central supercharged air cushion surrounded by an inner central air curtain and an outer or peripheral air cushion surrounded by a peripheral air curtain. The lift augmented ground effect platform of the present invention provides an increased or "large" augmentation of the forces acting to raise or lift the platform over that experienced in prior ground effect devices by directing an air flow stream over the downwardly curved peripheral surface of the platform. As the air flows downwardly along the curvature of the platform's peripheral surface, it creates a pressure differential which provides an additional force supporting the lifting of the platform. The airflow stream and the jet stream are provided by a propeller or rotating fan device mounted exterior of the platform. The exterior mounting provides two benefits: first, the propeller or fan stall due to the jet stream source is eliminated and second, smooth transition into free air (out of ground effect) is permitted where necessary to navigate rivers, canyons, and other types of physical barriers which may disrupt ground effect operation.

13 Claims, 7 Drawing Sheets

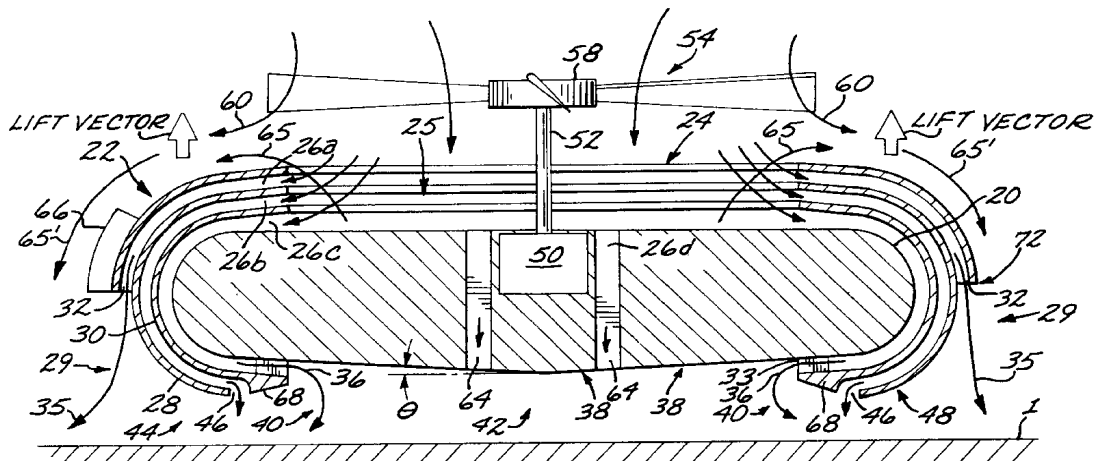

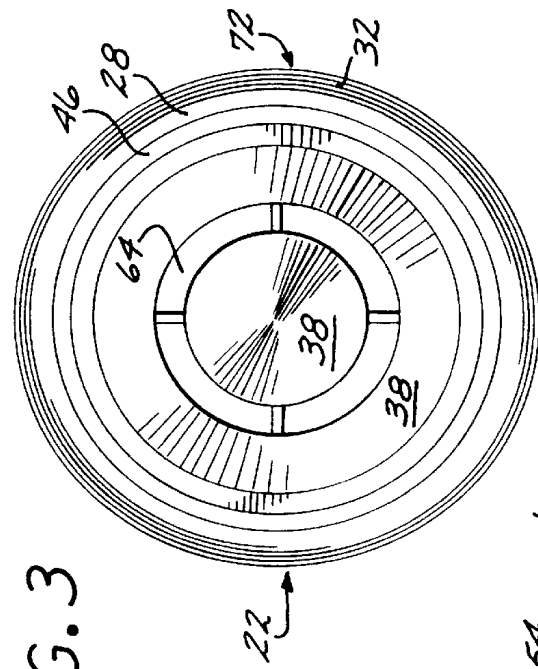

FIG. 3

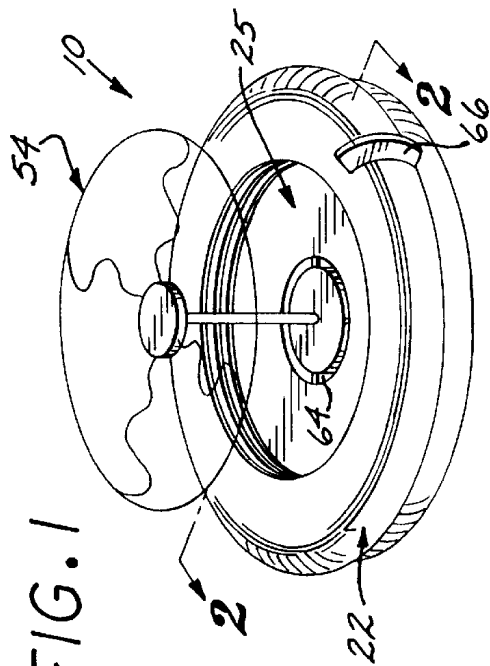

FIG. 1

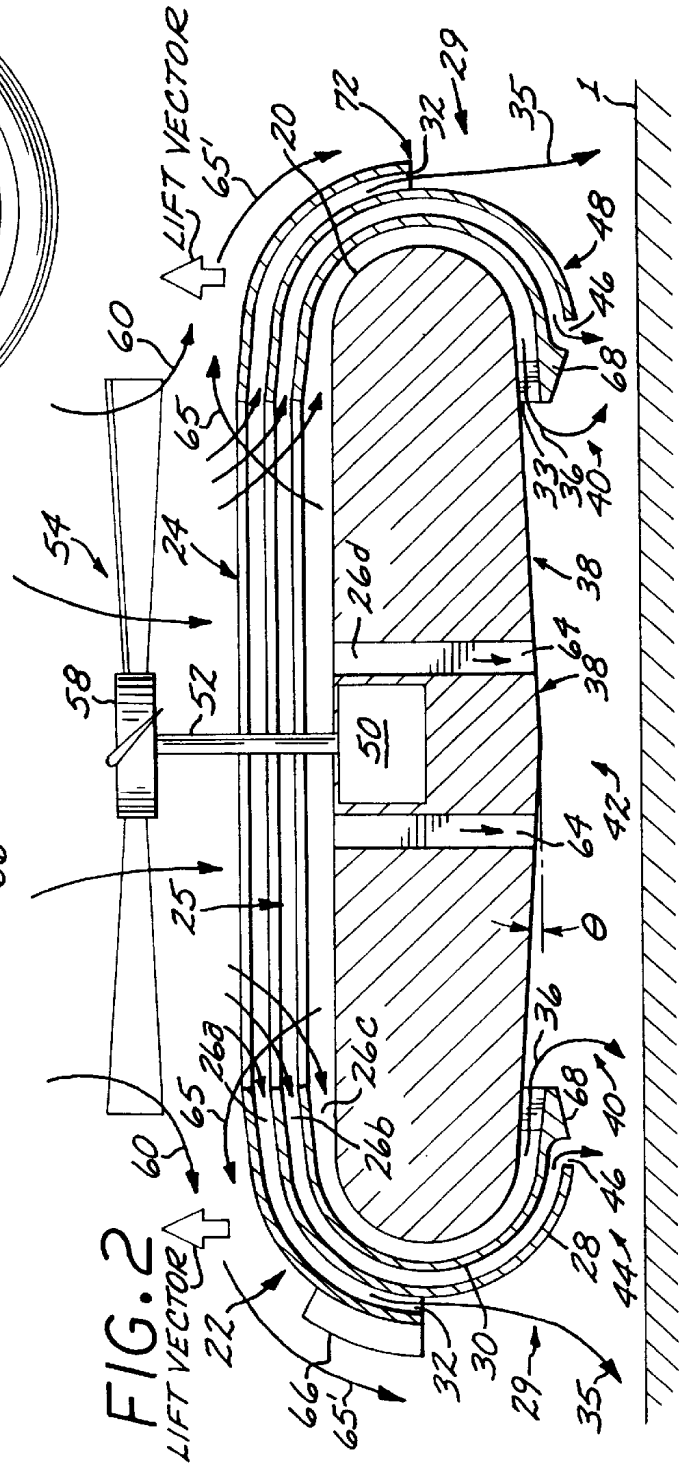
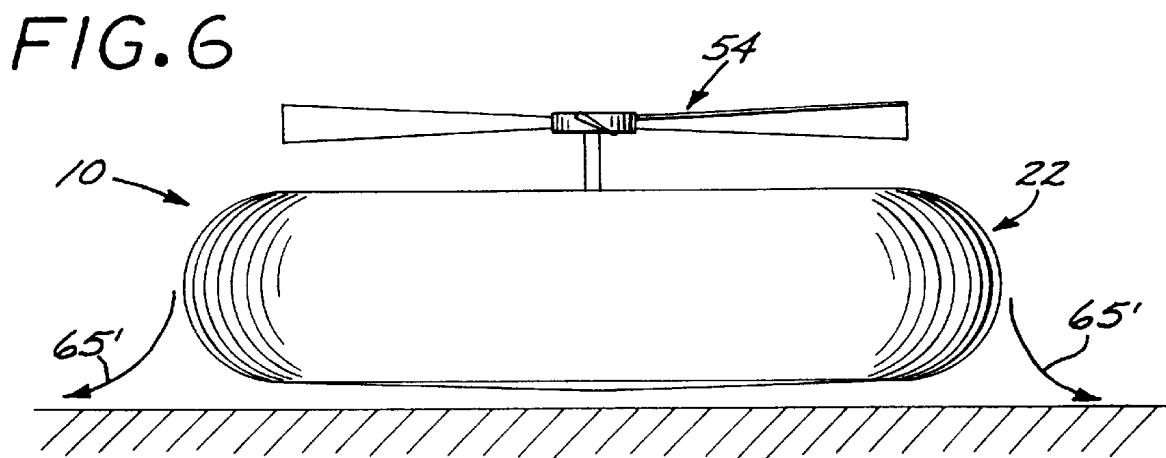
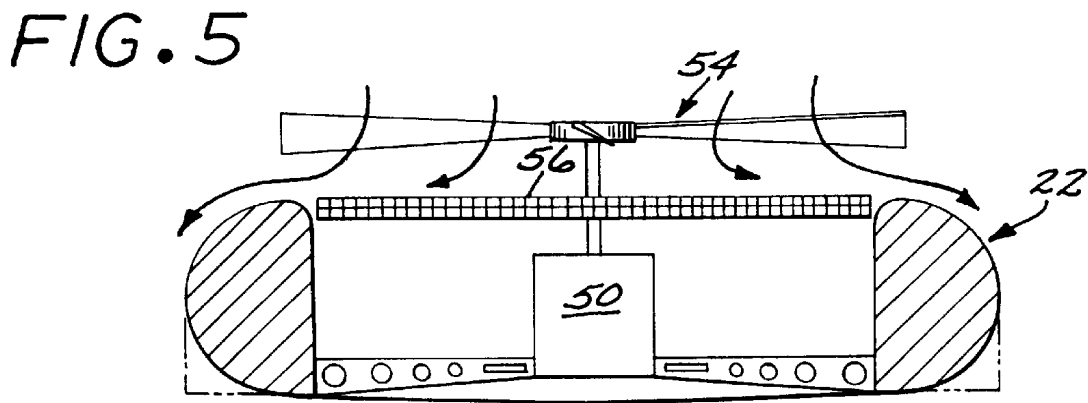
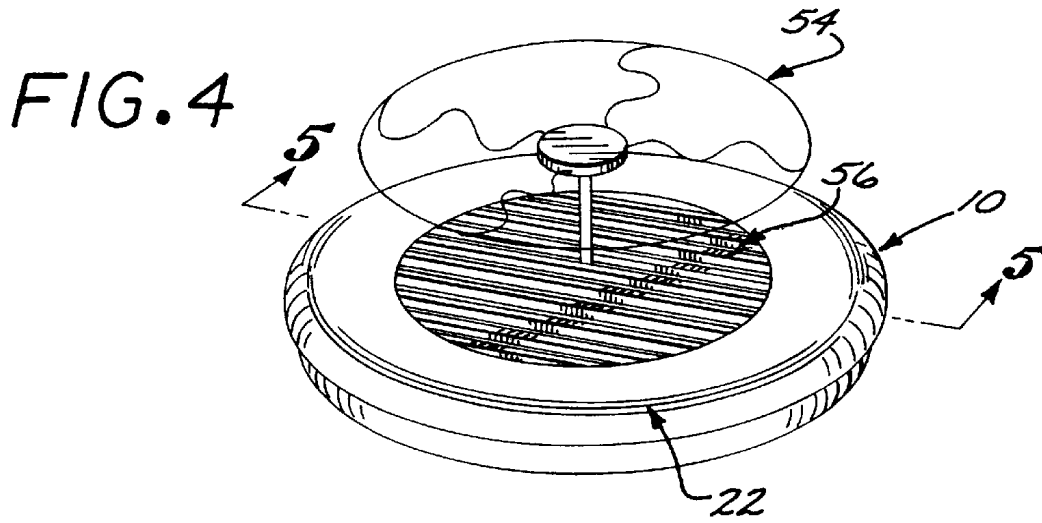

FIG. 2



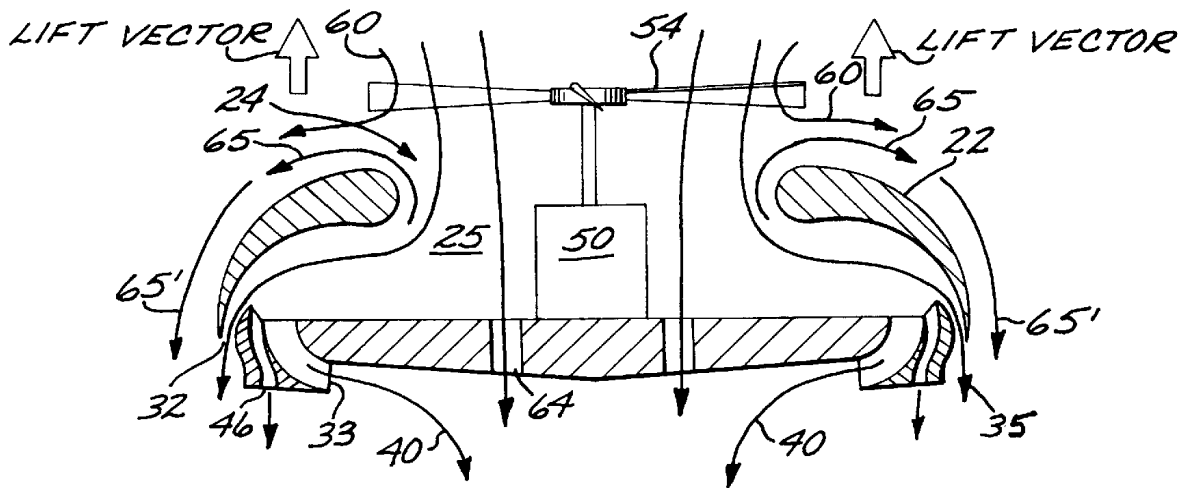

FIG. 7a

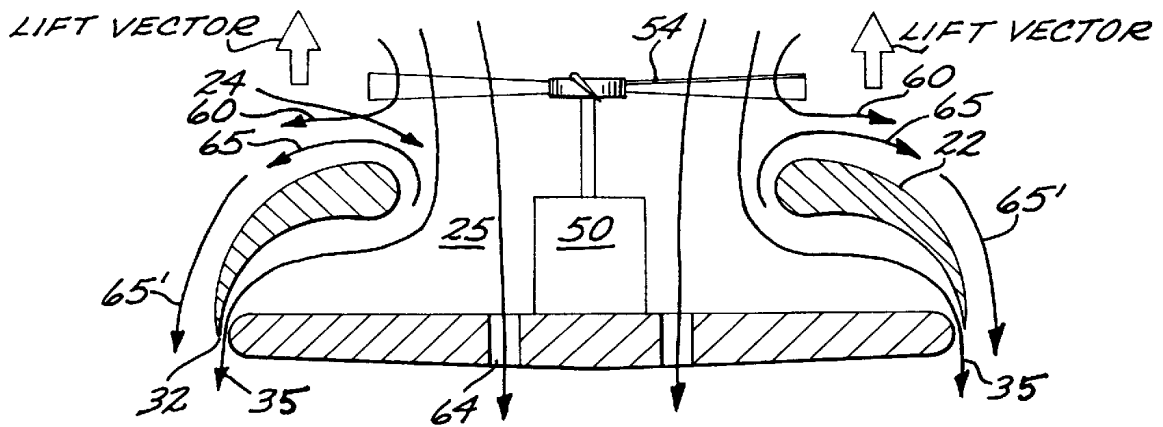

FIG. 7b

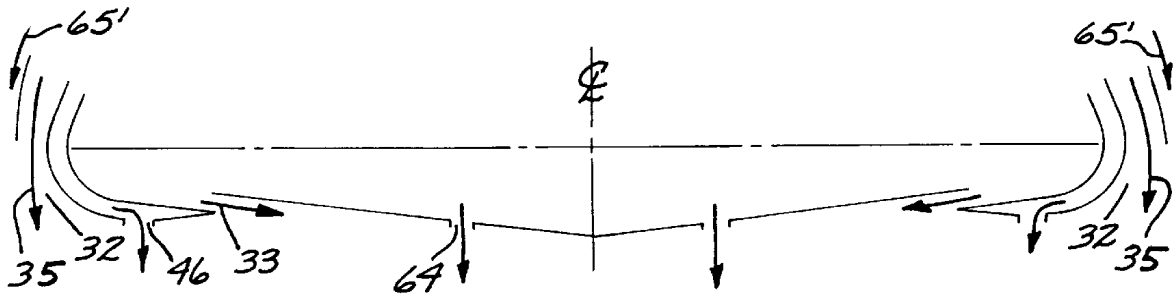

FIG. 8a

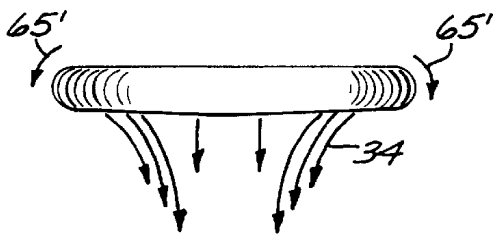

FIG. 8b

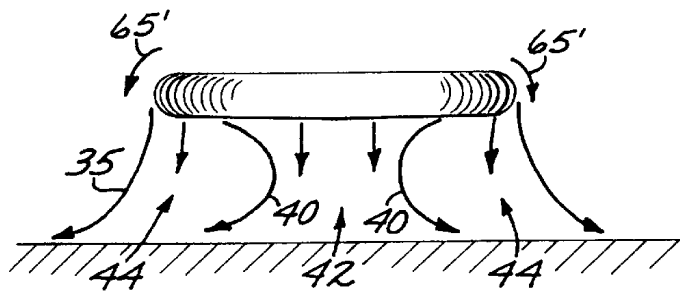

FIG. 8c

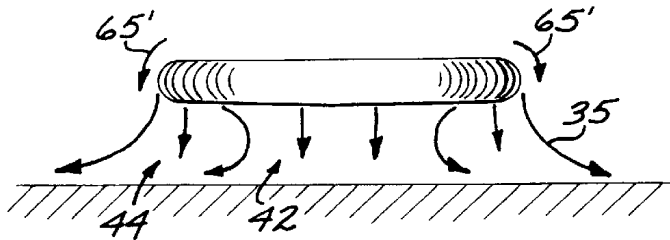

FIG. 8d

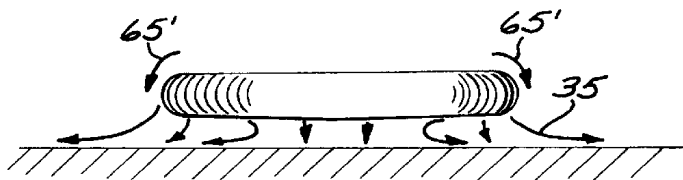

FIG. 8e

FIG. 9

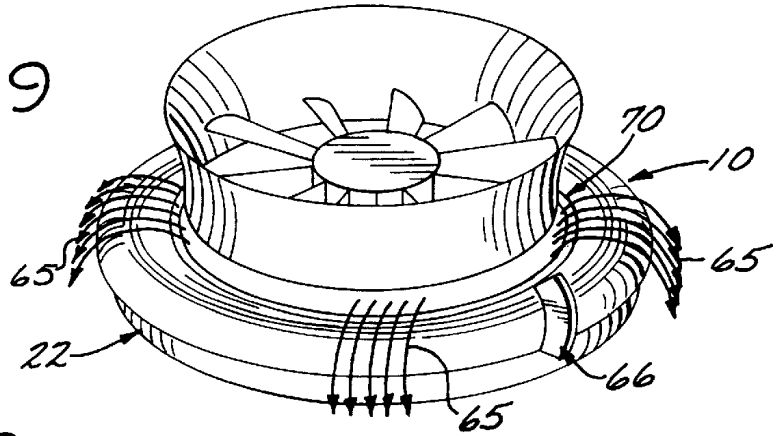

FIG. 10

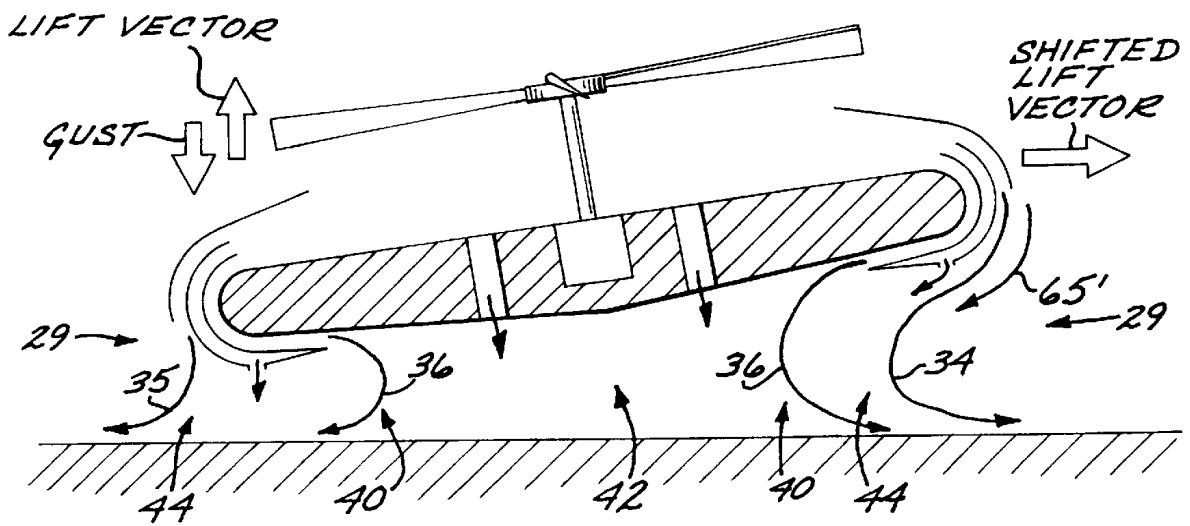

FIG. 11a

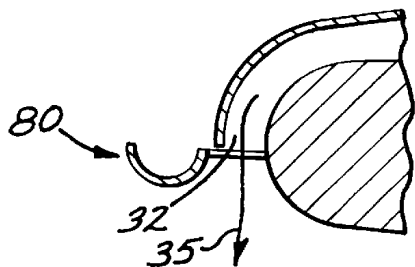

FIG. 11b

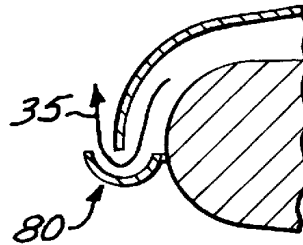

FIG. 11c

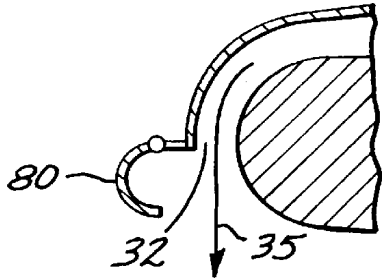

FIG. 11d

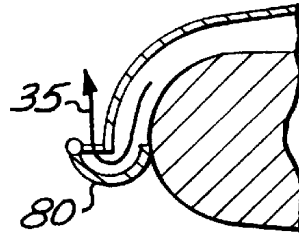
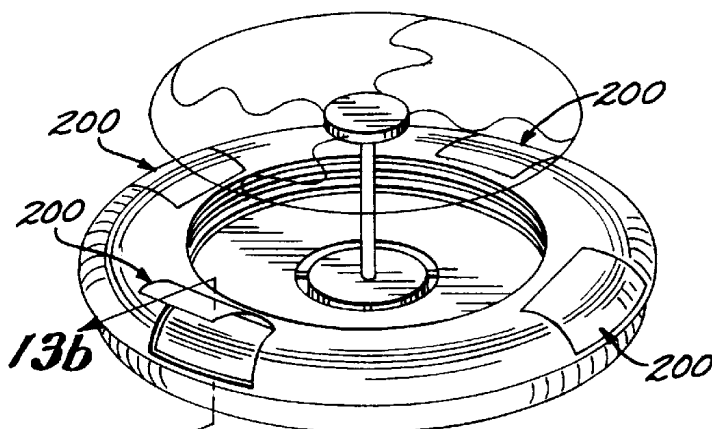
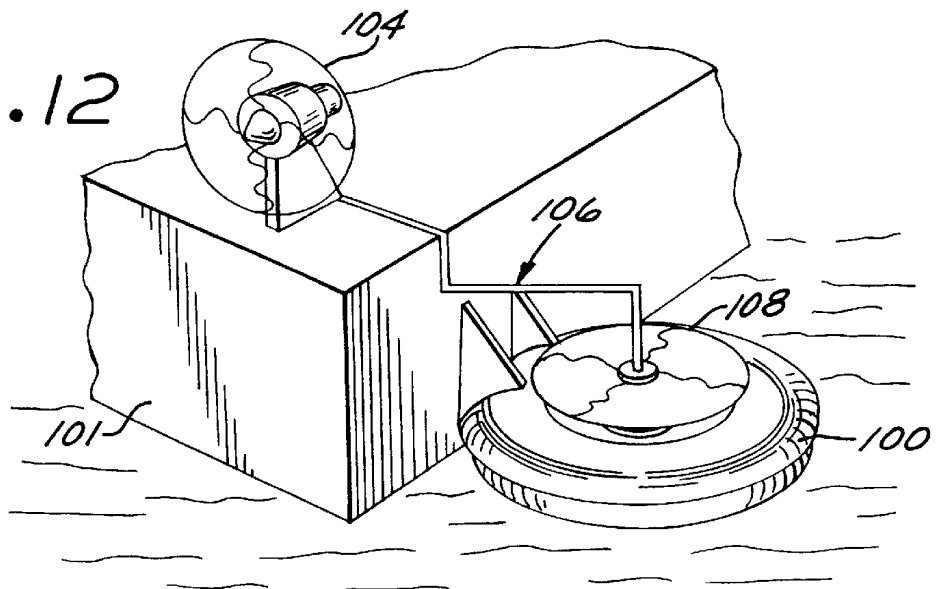

FIG. 12



13b FIG. 13a

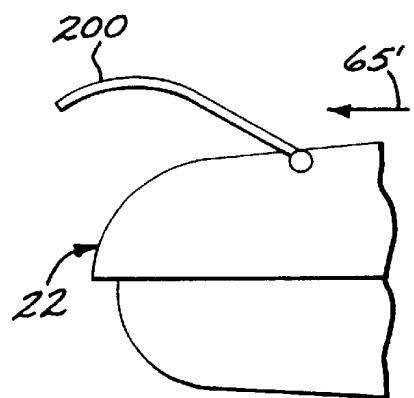

FIG. 13b

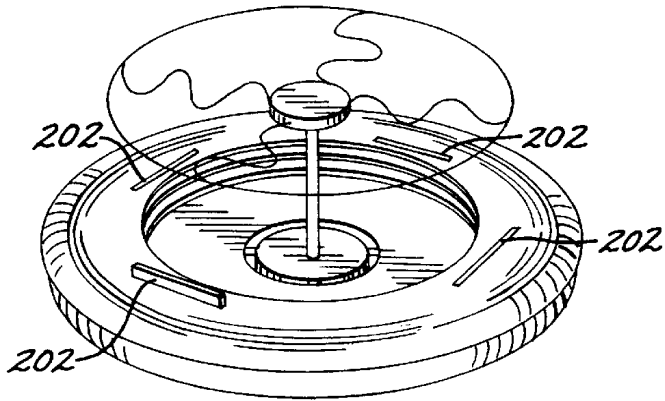

FIG. 14a

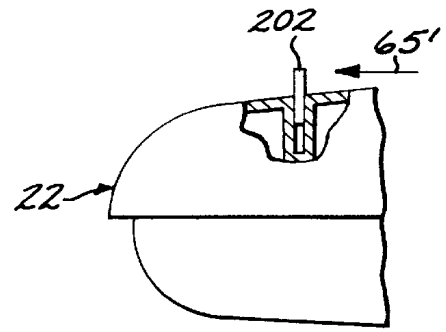

FIG. 14b

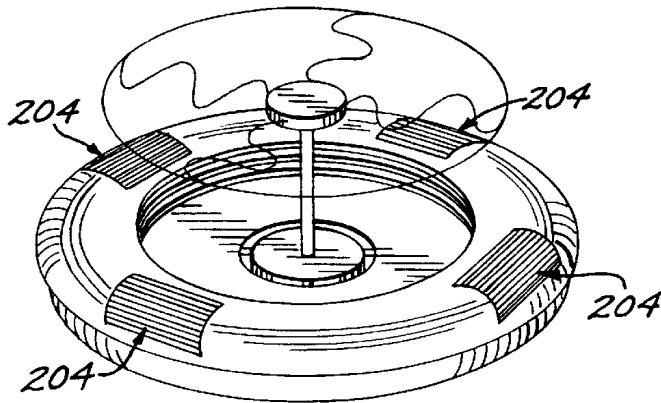

FIG. 15a

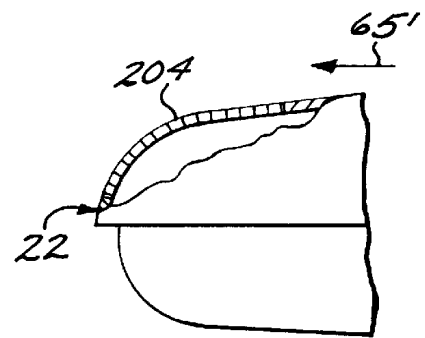

FIG. 15b

1

LIFT AUGMENTED GROUND EFFECT PLATFORM

FIELD OF INVENTION

The present invention relates generally to ground effect or air cushion devices and, more particularly, to ground effect devices operating without a skirt extending beneath the vehicle.

BACKGROUND OF INVENTION

Various types or designs of ground effect or air cushion devices have been developed over the years. These have included traditional hovercraft in which a physical skirt is provided about the bottom perimeter of the craft and an air stream is forced beneath the craft within the physical skirt providing a cushion of air which lifts the vehicle and maintains it at a predetermined operating height. These types of skirted hovercrafts have suffered from their inability to operate over uneven terrain and also their inability to climb or descend slopes or inclines. Furthermore, the presence of their skirts can create problems with their operation in certain environments.

Other types of ground effect or air cushion devices have included vehicles which include downwardly opening central jet nozzles which emit high pressure jet streams for forming central support columns and other vehicles which provide a peripheral jet stream for forming a peripheral air cushion for supporting the vehicle. These prior devices have suffered from a lack of stability when operated at a height above 10–20% of the vehicle's diameter.

Still another type of ground effect device is that depicted in the inventor's prior, now expired U.S. Pat. No. 3,747,726 ("Walter '726 patent") combining an interior support column of air with a peripheral curtain of air. Although intended to operate in a stable mode up to a height of 50% of its diameter and climb inclines, the device of the Walter '726 patent proved to be inoperative on a commercial scale.

A common feature of these prior air cushion or ground effect devices is that the air or jet stream producing source is positioned within the body of the device and during operation air is drawn into the body of the device and forced out of the undercarriage of the device, usually at high pressure. Such designs have restricted or limited the efficiency and operational parameters of the devices.

In addition to operational problems at heights above 10–20% of their external diameters and over uneven terrain or inclines, the prior ground effect vehicles also suffered from an inability to navigate physical barriers such as rivers, canals, ditches or the like. These types of obstacles or barriers present situations in which the operating surface (the ground) severely drops away forming a near vertical drop. Prior ground effect vehicles could not navigate these types of barriers.

Further, prior air cushion or ground effect devices have generally required a second propulsion system or means to provide horizontal movement to the device. The primary power or propulsion system was utilized to provide the lift or air cushion to the vehicle while a second power or propulsion system was required to move the device horizontally.

A need therefore exists for an improved, more efficient, ground effect or air cushion platform which can operate with stability at heights up to one-half the vehicle's diameter and move over uneven terrain and inclines. A need also exists for

2

an improved, more efficient, ground effect or air cushion platform which can navigate or transverse physical barriers such as rivers, ditches, canyons, etc. And a need exists for an improved ground effect or air cushion vehicle which derives its horizontal or forward motion from the same power source which provides the lift or air cushion.

SUMMARY OF THE INVENTION

The lift augmented ground effect platform of the present invention is characterized by two pair of annular concentric air curtain nozzles and supercharging nozzles which direct respective jet streams downward and inward beneath the downwardly facing lifting surface of the platform. The concentric arrangement of the nozzles provides an inner or central supercharged air cushion surrounded by an inner central air curtain and an outer or peripheral air cushion surrounded by a peripheral air curtain.

It is known that ground effect vehicles, when operating sufficiently close to the ground to be effected thereby, develop lifting force over that normally provided from the jet thrust. The increased lift experienced as a result of this ground effect of a particular vehicle is frequently termed "augmentation."

The lift augmented ground effect platform of the present invention provides an increased or "large" augmentation of the forces acting to raise or lift the platform over that experienced in prior ground effect devices by directing an airflow stream over the downwardly curved peripheral surface of the platform. As the air flows downwardly along the curvature of the platform's peripheral surface, it creates a pressure differential which provides an additional force supporting the lifting of the platform.

This airflow stream is provided by a propeller or rotating fan device mounted exterior of the platform. This propeller means is also the source of the jet stream which is directed into the interior of the platform and delivered through the pair of concentric annular air curtain nozzles and supercharging nozzles to provide the air cushion upon which the platform is raised or lifted.

The provision of the air or jet stream source (the propeller or fan) exterior of the platform body provides two benefits or enhancements for the subject invention. First, the external position of the jet stream source eliminates the problem of propeller or fan stall which may be experienced in ground effect devices constructed with the jet stream source within the body of device. Secondly, the external positioning of the jet stream source provides the previously described airflow over the exterior of the platform which allows the subject invention to smoothly transition into free air (out of ground effect) where necessary to navigate rivers, canyons and other types of physical barriers in which the operating surface necessary for a ground effect device becomes unavailable.

The ground effect platform of the subject invention can operate as a "stand alone" operational craft by means of control devices provided on the platform. The platform can be made to tilt in any direction, simply to counter any pitch and roll experienced by the platform or to move in a horizontal direction. This is accomplished by disrupting the airflow over the exterior of the platform which disrupts or decreases the amount of lift being generated over that portion of the platform. Alternatively, the air stream exiting the peripheral air curtain nozzle may be selectively disrupted, again resulting in a tilting of the platform which will result in horizontal movement of the platform.

The transition from simply vertical, air cushion, movement of the platform to actual forward or horizontal move-

ment is accomplished entirely from the manipulation of the power source and the jet stream that provides the air cushion.

The stability of the lift augmented ground effect platform of the subject invention is provided by a platform lifting surface which curves upwardly and outwardly from the bottom of the platform to form an arcuate restoring surface which is positioned with respect to the outer or peripheral air curtain nozzle. When a disturbance such as a gust is sufficient to cause the pitch or tilt down of one side or other of the vehicle, the vehicle rotates about its center of gravity: one side goes down and the opposite side goes up. This causes the upside peripheral nozzle system to be elevated to an operating height in excess of its design equilibrium position. The peripheral nozzle is designed to function in free air (out of ground effect) as a coanda nozzle with the air exiting the nozzle attaching to the downwardly and inwardly curving surface skin (restoring surface) which connects with the bottom skin of the vehicle. When operating in ground effect, the back pressure of the peripheral air cushion prevents the air curtain wall exiting the peripheral nozzle from attaching (i.e., in ground effect, the peripheral nozzle does not function as a coanda nozzle). Now, in response to a gust pitching one side of the vehicle down, the opposite side is suddenly elevated to conditions which the elevated nozzle sees as free air conditions. Instantaneously, this part of the elevated peripheral nozzle begins to function as a coanda nozzle and the airflow attached to the curved underside and flows downwardly and inwardly under the vehicle bottom-side. A part of the lift vector which was producing lift around the top surface of the periphery of the vehicle, that part affected by the coanda nozzle suddenly functioning shifts from vertical, pointing up, to horizontal, pointing away from the vehicle body. These changes occur simultaneously. The immediate result is a very strong restoring moment which develops because the lift vector on the pitched down side is still there and functioning to lift that side up again, as is gravity working to drop the side of the vehicle with the now more active coanda nozzle.

The lift augmented ground effect platform of the present invention is intended to be operable both as a self-contained unit and as a lifting and landing power unit utilized in conjunction with another platform or body.

Accordingly, it is an object of the present invention to provide a ground effect platform of the type described which exhibits a relatively large augmentation in lift up to heights approximating the physical diameter of the platform.

Additionally, it is an object of the present invention to provide a ground effect platform of the type described which is self-stabilizing at all operating heights.

Another object of the present invention is to provide a ground effect platform which can operate stably at heights greater than previous ground effect platforms.

A further object of the present invention is to provide a ground effect platform which operates more efficiently when operating in ground effect mode.

Still another object of the present invention is to provide a ground effect platform which can operate over relatively tall obstructions and negotiate relatively steep inclines.

And, yet another object of the present invention is to provide a ground effect platform which can transition from ground effect to free air for traversing physical barriers which remove the operating surface from the platform.

Still further, it is another object of the present invention to provide a ground effect platform which utilizes the energy of the power source creating the air cushion and lifting force to impart horizontal or forward motion to the platform.

These and other objects and the advantages of the present invention will become apparent from a consideration of the following detailed description when taken in conjunction with the accompanying drawings.

DESCRIPTION OF THE DRAWINGS

FIG. 1 is a perspective view of the lift augmented ground effect platform embodying the present invention;

FIG. 2 is a cross sectional side view taken along the line through the center of the platform dividing it into two equal sectional halves;

FIG. 3 is a bottom plan view of the ground effect platform shown in FIG. 1;

FIG. 4 is a perspective view of the subject invention illustrating the louvered embodiment utilized for out of ground effect operation of the platform.

FIG. 5 is a side view of the subject platform illustrating the airflow pattern when the louvers are placed in a closed position.

FIG. 6 is a schematic of the platform shown in FIG. 5 illustrating the non ground effect nature of the platform when the intake louvers are closed.

FIG. 7a is a schematic drawing of the airflow patterns in the preferred embodiment of the nozzle configurations of the subject invention.

FIG. 7b is a schematic drawing of the airflow patterns in an alternate embodiment of the nozzle configurations.

FIG. 8a is a schematic drawing of the nozzle and airflow configuration illustrated in FIG. 2.

FIG. 8b is a schematic of the airflow pattern of the platform operating in free air.

FIG. 8c-8e are schematic illustrations of the airflow pattern when the platform is operating at varying heights in ground effect.

FIG. 9 shows an embodiment of the subject invention in which the propeller is shrouded.

FIG. 10 is a schematic of the subject invention illustrating the forces acting upon the platform when it is disturbed from equilibrium.

FIG. 11a-11d illustrate alternative embodiment of reverse thrusts for controlling pitch and roll.

FIG. 12 shows the subject platform used in connection with another vehicle.

FIG. 13a and 13b show a first embodiment of control apparatus for the subject platform.

FIG. 14a and 14b show a second embodiment of control apparatus for the subject platform.

FIG. 15a and 15b show a third embodiment of control apparatus for the subject platform.

DESCRIPTION OF THE PREFERRED EMBODIMENTS

Referring to FIGS. 1, 2 and 3, the basic lift augmented ground effect platform of the present invention includes, generally a body 10 formed with a circular or symmetrical, near circular core 20 which is covered by an outer annular skin 22. The symmetrical near circular configuration could be a polygonal configuration which approximates a circle, such as an octagon. The cover skin 22 is formed with a central opening defining a jet intake 24 and is spaced from the core 20 to form triple arcuate ducted flow paths 26a, 26b, and 26c extending radially outward, curving downwardly around the arcuate periphery of the core 20. A pair of arcuate

dividing rings **28** and **30** are interposed in the passage between the annular skin **22** and the core **20**. The divider ring **28** closest to the annular skin **22** provides a duct for air entering at the uppermost air intake **26a** and exiting from a peripheral downwardly facing air curtain nozzle **32** which directs a peripheral jet stream **35** downwardly and eventually outwardly in the presence of a horizontally oriented operating surface. Jet stream **35** forms a peripheral air curtain **29** which encircles the outside periphery of body **10**. The divider ring **30** closest to the core **20** provides a duct for air entering at intake **26c** and exiting from a central air curtain nozzle **33** which opens inwardly to direct an annular central jet stream **36** inwardly along the bottom surface **38** of core **20** until it encounters opposing airflow from nozzle **64**, that causes it to turn downwardly and then curve outwardly to form a central air curtain wall **40** of circular configuration from within which is formed a central air cushion plenum chamber **42** providing lift or supporting part of the platform weight. The central air curtain wall **40** cooperates with the peripheral air curtain wall **35** to form an annular-shaped peripheral plenum chamber **44** that provides a lifting or supporting force on the platform throughout an annular section of the downwardly facing lifting area **38**, the downwardly facing exposed external surface of the core **20**. Air is provided to peripheral plenum chamber **44** via duct path **26b** which is formed between dividing rings **28** and **30**. The air or jet stream is delivered to chamber **44** by means of peripheral charging nozzle **46**. The referenced dividing ring **28** is arcuate in vertical cross section to form an upwardly and outwardly curved restoring surface **48** that surrounds the lifting surface **38** (the exposed undersurface of central core **20**).

In the preferred embodiment, the diameter across the central air curtain nozzles is 0.707 of the diameter of the peripheral air curtain nozzles. This provides equal working area within each air cushion chamber **42** and **44**.

A jet stream is introduced into central air cushion plenum chamber **42** by means of ducts **26d** positioned through the body of the core **20**. Central air cushion or supercharging nozzles **64** are provided for directing the jet stream into air cushion chamber **42**.

In a preferred embodiment, the base of the underside of the platform represented by the exposed lifting surface **38** of the core **20** has a dihedral configuration with angle theta, θ , to assist in providing inherent static and dynamic stability in pitch and roll modes.

Referring to FIG. 2, the central core **20** contains or supports power source **50** preferably a conventional internal combustion or turbo shaft aircraft or helicopter engine. Alternate locations for the power source within core **20** will be obvious to those skilled in the art. The power source transmission **52** drives a conventional aircraft single or multi-bladed propeller **54** or a single stage axial fan. As will be discussed in detail later, the propeller or fan **54** may be either shrouded or unshrouded depending upon the particular operating parameters associated with the particular application of the platform of the subject invention. As illustrated in FIG. 2, the propeller or fan **54** is positioned above and external to the body **10**, the propeller **54** is aligned with jet intake **24** which intake opening may be equipped with a remotely controllable louvered cover **56**. See also, for example, FIG. 4. Jet intake **24** opens into internal cavity **25** which feeds the air or jet stream to the air ducts **26a-d**.

In a preferred embodiment, the propeller or fan diameter is larger than the jet intake opening **24** diameter, extending at a minimum over the top of the platform annular cover skin

22 to a point where the surface of the cover skin **22** begins to curve downwardly as it begins its arcuate segment approaching the periphery of the platform. This is illustrated in FIG. 2. Thus, assuming the louvered jet intake cover **56** is open, ambient air entering the propeller near the propeller hub **58** will enter through the jet intake **24** into internal cavity **25** wherein it will be introduced into the internal ducting system, ducts **26a**, **26b**, **26c**, and **26d**, exiting through the nozzles **32**, **33**, **46** and **64** respectively, whereas air **60** passing through the propeller tips or ends will flow downwardly and outwardly, as shown by air stream **65** over the outside of the cover skin **22** without entering the platform intake **24**. Air entering the intake plenum through the open louvered cover **56** will either enter the peripheral ducting system **26a**, **26b**, **26c** or flow through the vertically positioned central supercharging ducts **26d** located in the center of the platform core **20**. Supercharging air entering the duct **26d** will exit nozzle **64** into the pressurized central air cushion plenum chamber **42** formed under the central region of the underside of the platform within the central annular air curtain wall **40**. The peripheral air cushion plenum chamber **44** is also supercharged by air exiting from the peripheral charging nozzle **46**. "Supercharging" as used herein refers to forcing a greater mass of air into the peripheral and central air cushion plenum chambers **42** and **44** respectively than they contain in a normal state as the result of their formation within air curtain walls **29** and **40** within which the air cushions are contained.

Still referring to FIG. 2, it should be noted at this juncture that the ground effect platform of the present invention is supported above its operating surface **1** by three separate, distinct, and independent sources of lift. The first source of lift is momentum thrust from the air jet stream exiting air curtain nozzles **32** and **33** and supercharging nozzles **46** and **62**. The second source of lift is the force or pressure of the air cushion acting upwardly against the lifting surface **38** on the underside of the body **10**. The third source is aerodynamic lift created by the flow of air over the peripheral outwardly and downwardly facing surface of the cover skin **22**. The phenomena producing this aerodynamic lift is commonly known as the coanda effect or coanda principle.

Extensive testing of dynamically similar scale models of the subject lift augmented ground effect platform have confirmed the existence of these three distinct sources of platform lift when said platform is operating in close proximity (ground effect) to an operating surface up to a stand-off height of approximately 50% of the platform diameter. Testing has further shown that the lifting force generated by airflow over skin **22** increases at a greater rate than the other two sources of lift as power is increased. With the application of sufficient power, the subject ground effect platform configured as described above can be made to operate in free air (out of ground effect). It has also been demonstrated that upon closing the louvered intake **58** (no air entering the internal ducting system) that the platform of the subject invention will also operate in free air.

Those skilled in the art will recognize and understand the physical principle that a jet or air stream can be caused to follow a curved path defined by one wall or surface by merely moving a second wall or surface sufficiently close to the first surface to reduce the thickness of the airflow passage defined between said two surfaces below a critical thickness. This critical thickness for air is defined by the equation $t/R=0.344$ where t is the distance between the two surfaces and R is the radius of curvature of the curved surface. When the flow passage is reduced below this critical thickness, the jet stream will be induced to follow the

general curvature of the curved wall. This principle is utilized in connection with design or sizing of both the peripheral air curtain nozzle **32** and the central air curtain **33** nozzle. This design configuration results in central air curtain stream **36** following the curved contours of surface **38** during normal operation of the platform. When the platform is operating in ground effect, jet stream **35** does not follow the curved surface of ring **28**, even though nozzle **32** is configured as a "coanda" nozzle. This is due to the back pressure created in peripheral air cushion chamber **44**. When the platform is operated in free air (out of ground effect) then jet stream **34** follows the curved surface of ring **28**.

Utilizing the design criteria discussed above, the ground effect platform of the subject invention achieves operating efficiencies over prior ground effect or air cushion vehicles. Through model testing it has been determined that by providing for the exterior airflow over the curved skin cover **22** the subject platform achieves approximately a 40% increase in the height of the platform over a platform in which airflow is not allowed over skin cover **22**. This enhanced augmentation of the ground effect lifting force is obtained without providing any additional power to the propeller or fan **54**.

During operation, air entering the jet intake plenum **24** through the open louvered cover **56** (see FIG. 4), may build up an over pressure or back pressure as the air is forced through the peripheral duct paths **26a**, **26b**, and **26c** and the supercharging duct **26d**. The amount of air which will flow through ducts **26a-d** will vary depending upon the load (weight) imposed upon the platform in a particular application or operation. This in turn creates a varying degree or level of back pressure. Excess back pressure could result in propeller or fan stall. Prior devices, such as that depicted in the Walter '726 patent suffered from propeller stall. The ground effect platform of the subject invention automatically prevents this excess pressure build up by allowing excess air mass **65** to exit chamber **25** and flow over surface **22**. As can be understood from FIGS. 2, 5, 7a, 7b and 9, exiting airflow stream **65** joins the flow **60** of air provided through the propeller tips and flows along the curved surface of skin **22** as previously described as airflow **65'**.

In operation, the rotation of the propeller or fan **54** will tend to impart a rotational force or torque to the platform body **10**. To counteract this torque a plurality of anti-torque vanes **66** are provided on the periphery of the surface **22** as shown in FIGS. 1 and 2. These anti-torque vanes **66** may be curved to direct the airflow **60**, **65** and **65'** in a direction to more efficiently counterbalance the torque generated by the rotating propeller **54**. Additional trimming vanes **68** are provided at the central air curtain wall nozzle **33**. Anti-torque vanes **66** and trimming vanes **68** may be fixed or they may be adjustable by various means known to those skilled in the art.

In order for the air stream **65'** to be induced to attach or follow the curved surface **22** an actuating device referred to as a coanda tripper is required. This "tripper" or air flow entrainer, acts as the second wall or surface through which the air stream flows. In one embodiment, the positioning of the propeller **54** the proper distance from the platform so that the vortex airflow from the tip of the propeller or fan, impinging on the surface of skin **22** serves as the tripper causing the external flow of air **65'** over the skin **22** to attach or flow in an arcuate path along the curved contour of the outer skin **22**. This configuration is illustrated in FIG. 2.

Referring to FIG. 9, an alternate form of coanda trippers in the form of peripheral "barrel hoop" rings **70** is illustrated.

The rings **70** or trippers act as the second surface in the coanda nozzle and induce the air flow **65'** over skin surface **22** to attach and follow the curved surface. The rings **70** may be attached to the upper surface by any number of different types of supporting device, such as struts, which are not shown in this drawing. FIG. 2 shows additional "tripper" devices **72** located at the periphery of the platform to induce the airflow attached to the upper surface of the platform to remain attached and flow downwardly and inwardly under the dihedral lifting surface of the platform, thus increasing the efficiency of the platform in free air operation. These additional tripper devices **72** may be mounted on a circular ring extending about the peripheral edge of the platform body **10**. In a preferred embodiment, these would be adjustable, such as by pivoting towards or away from the platform to selectively induce the airflow to follow the curvature of the platform.

Referring to FIGS. 7a and 7b, the airflow patterns of two alternate combinations of ground effect platform exit nozzle configurations are illustrated. FIG. 7a illustrates the exit airflow patterns with a simplified ducting system including provision for supercharging. Air is driven by the propeller through intake **24** and into chamber **25**. The air flows into the duct system and exits the nozzles as previously described. Excess air **65** exits the chamber **25** and flows over curved surface **22**, along with additional air streams **60** and **65'**. FIG. 7a illustrates in a somewhat simplified fashion the airflow patterns previously discussed in connection with FIG. 2. FIG. 7b illustrates the airflow pattern in an alternate embodiment in which only a peripheral air curtain nozzle and central air cushion nozzle are provided.

FIG. 8a illustrates the generalized configuration of exit nozzles **32**, **33**, **46**, and **64** for the ground effect platform of the present invention. FIGS. 8b through 8e illustrate the airflow pattern which exists at various heights above the operating surface including free air. As discussed previously, the peripheral nozzle **32** only functions as a coanda nozzle (i.e., induces the airflow exiting the nozzle to attach to the curved surface) when the platform is operating in free air. This is illustrated in FIG. 8b. In this configuration, air stream **34** curves under the platform. FIGS. 8c-e illustrate the airflow patterns at varying heights with ground effect. As shown, the air stream **34** curves downwardly and outward with respect to the platform.

FIG. 9 illustrates the utilization of a shrouded prop or shrouded single stage axial fan as the power source for the platform.

FIG. 10 illustrates the means by which inherent static and dynamic stability in pitch and roll modes is achieved with this nozzle configuration. When a gust generates a downward force on the bow of the platform the following is the reaction: 1) The nose of the platform pitches downward. 2) The air flow from the bow curtain wall **29** continues to exit directly in line with the physical exit nozzle direction (downward). This portion of the bow curtain wall **29** does not respond as a coanda nozzle due to the back pressure of the peripheral cushion **44** which prevents this performance. 3) The center of gravity of the platform drops only a very small fraction in reaction to the gust since the central supercharged cushion **42** sustains the stand-off height and the platform tends to rotate about its center of gravity. 4) The stern of the platform opposite the bow, is above the plane of the center of gravity thus creating a condition on the rear coanda nozzle such that, due to its elevation above the equilibrium condition the stern air curtain wall **29** no longer experiences the cushion back pressure. Behaving normally as a coanda nozzle, a large portion of the peripheral air

curtain wall **25** attaches to the curved part of the coanda nozzle, curving inwardly and downwardly along restoring surface **48**, as shown by air stream **34**, beneath the underside of the platform. 5) The action of the coanda nozzle creates a negative pressure thus drawing in ambient air and further induces the air flow **65'** over the curved skin **22** to attach with the flow **34** induced under the platform stern. A lift force is also created in the plane of the platform extending rearward. 6) The horizontal component of the lift vector has a moment arm above the center of gravity which creates a strong restoring moment acting in opposition to the gust force. When the gust departs the restoring moment acts to restore equilibrium within a 1½ cycle restoration period.

Control in pitch and roll mode is accomplished by moving reverse thrust (semicircular shaped troughs) into air stream exiting the peripheral the air stream **35** wall exit nozzle. This is illustrated in FIGS. **11a–11d**. These reverse thrust devices **80** occupying the bow and stern regions on the platform and also both left and right sides of the platform. They are actuated by remote control means (not shown) or by a human operator employing a simple bellcrank and pulley system (not shown) when moved into the airflow these reverse thrust devices **80** produce a thrust which produces a downward pitching moment, pitching the nose down or up as desired or banking the platform to the right or left as desired (drawing not shown). Thus the platform can be made to accelerate into horizontal translative motion or stopped (braked) with this control system. Also, this pitch control mechanism allows the platform operating at stand-off heights approaching ½ platform diameter or width to climb steep slopes (up to 20 degrees and descend steep slopes). As shown in FIG. **11a** and **11b**, the reverse thrusters may be slidably moved into the air stream, or as shown in FIG. **11a** and **11d** they may be rotated or pivoted about a hinge into and out of the air stream.

Having described the construction and operation of the basic improved ground effect platform of the subject invention, alternate embodiments of the invention for particular applications will be described.

As described and illustrated, the subject platform may be employed as a lifting and landing device to provide vertical movement to another body or device. One such embodiment of this application is depicted in FIG. **12**.

In this embodiment, the platform **100** is connected to or mounted on another vehicle, such as a wing in ground (“WIG”) effect vehicle **101**. Such vehicles operate in ground effect, however, they utilize the lift from traditional wings rather than an air cushion to provide the lift. Such vehicles suffer, however, from the requirement of carrying additional propulsion units or systems needed to provide the initial vertical lift of the vehicle and support it above the operating surface until such times as the vehicle has achieved sufficient horizontal speed to effect adequate lift off of its wings. Once it is operating in the WIG mode, less energy or force is required to maintain its forward motion than was required to obtain the initial lift. Thus, such vehicles are forced to carry the weight of the excess lifting capacity.

As shown in FIG. **12**, utilization of the subject platform solves this problem traditionally encountered in WIG vehicles. The WIG vehicle is powered by the WIG propulsion system **104**. This may be a fan jet, turbo prop or other known systems utilized for providing power or thrust to “winged” vehicles To eliminate the weight and inefficiency of carrying a separate power source to provide the initial vertical lift of the WIG the platform **100** is provided with a hydraulic propulsion system which is driven or powered by

the WIG propulsion system **104**. Hydraulic power lines **106** are provided which connect the WIG propulsion unit with the platform hydraulic power unit. In this embodiment, the propeller **108** of the platform **100** is driven by the hydraulic power unit. The platform provides lift as previously described. Thus, the WIG vehicle is lifted off of its operating surface by the same propulsion unit which provides its forward thrust. No additional power units or fuel are required. Once the WIG vehicle has risen a sufficient height, its forward motion provides lift off of its wings sufficient to sustain the vehicle in ground effect flight and the lifting force of the platform **100** is no longer needed. At that time the hydraulic power unit may be turned off and the platform is essentially “turned off.” In order to reduce air drag, the platform **100** may be connected to the WIG vehicle on retractable supports, similar to the landing gear of an airplane, which would allow the platform **100** to be retracted out of the airflow.

Alternate means of connecting the platform to a WIG or other type of vehicle will be readily apparent to the those skilled in the art.

Similarly, other means of powering the platform **100** off of the WIG propulsion system **104** can be used. These include rotating one unit of the WIG system downward to direct its thrust over the platform thereby providing lifting through the platforms ducting and nozzle system and through the airflow over the exterior of the platform. Upon achieving the correct lift off height and sufficient forward motion this power unit could be rotated back to its normal operating position to provide forward thrust to the vehicle.

It must be understood that when utilizing the subject invention as a lifting and landing platform for other vehicles, a minimum of two platforms will need to be utilized to provide the necessary lift and to provide operational stability to the WIG or other vehicle.

As previously discussed, the subject ground effect platform is also intended to function as a “stand alone” air cushion vehicle. This may be in either a manned or unmanned, remotely controlled configuration. In the stand alone mode, the platform must be provided with control systems for providing directional control to the platform. Alternate embodiments of control systems are shown, respectively, in FIGS. **13a** and **13b**, **14a** and **14b**, and **15a** and **15b**.

The first embodiment shown in FIG. **13a** and **13b** utilizes a “control panel” design. In this embodiment, areas in the bow, stern, port and starboard sides of the peripheral skin **22** are provided with rectangular shaped control panels **200** hinged along the inner edge of intake **24**. By raising one of the panels **200** as shown in FIG. **13b** the air flow is disrupted in that location which spoils or disrupts the lifting force over that section of the platform. This will result in the lowering or dropping of that portion of the platform. This controlled pitching of the platform will result in the formation of a horizontal force vector which provides horizontal movement to the platform.

A second embodiment of the control mechanism is shown in FIG. **14a** and **14b**. This is a “spoiler system” in which spoiler plates **202** are retractably mounted in the platform body. When the spoiler plate **202** is raised upward into air stream **60**, **65** and **65'** it disrupts the airflow and lift causing that side of the platform to drop.

Finally, in FIG. **15a** and **15b** another embodiment is shown in which a louvered panel is utilized. In operation, the louvers are normally closed allowing for airflow over the platform. By raising the louvers **204**, the airflow is disrupted and that portion of the platform tilts or drops.

11

As discussed, one of the features of the subject invention is its ability to operate out of ground effect or in free air. This feature enables the subject platform to navigate physical barriers such as rivers and canyons where the operating surface (ground) suddenly drops off or is otherwise unable to provide an air cushion support for the vehicle. To operate in free air, the air intake **24** is provided with a rotatable louvered closing system as shown in FIG. **4**. In normal ground effect operation, louvers **56** are maintained in an open position. This allows for airflow into the platform and through the duct system to provide the air cushion support for the platform.

When it is desired to operate the platform out of ground effect, the operator closes the louvers **56** which blocks off the duct and nozzle system. This results in all of the jet stream generated by the propeller **54** to flow over the curved skin **22**. This increased airflow creates an increased aerodynamic lift over surface **22** which enables the platform to travel or “fly” in free air. Thus, unlike other ground effect air cushion devices the present invention can be operated effectively without a supporting or operating surface. When operating in free air, it must be noted that the power source must be operated at a higher level than when operated in ground effect in order to provide sufficient lift to the platform.

From the foregoing detailed description, it will be apparent that the ground effect platform of the present invention is relatively stable and develops restoring forces which tend to stabilize the platform whenever it has been subjected to any unstabilizing force thereby enabling such platform to operate at greater heights than conventional platforms. It is believed that ground effect platforms constructed in accordance with the present invention will operate at heights of approximately 50 percent of their diameter as contrasted with the presently known platforms which are unstable when operating at a height in excess of 10 percent or 20 percent of their diameter. Consequently, platforms can be made with sufficiently small diameters to enable them to have access to areas that would otherwise be inaccessible and such platforms can operate at a height which will enable them to negotiate over obstacles which would otherwise force selection of alternate routes.

Various modifications and changes may be made with regard to the foregoing detailed description without departing from the spirit and scope of the invention.

What is claimed is:

1. An augmented ground effect platform comprising:

a substantially circular body formed with a downwardly radially curved exterior peripheral surface;

a downwardly facing lifting surface formed on the underside of said body;

a peripheral restoring surface extending around said lifting surface and angling upwardly and outwardly with respect thereto;

an air intake cavity formed in the upper surface of said body;

concentric annular nozzle means, including a first air curtain nozzle, a first air cushion nozzle, a second air curtain nozzle and a second air cushion nozzle;

first air passageway means connecting said intake cavity with said first air curtain nozzle, first air cushion nozzle and second air curtain nozzle;

second air passageway means connecting said intake cavity with said second air cushion nozzle; and

an air drive means, said air drive means being positioned exterior of said body for directing a jet flow into said air

12

intake cavity and also over the curved exterior peripheral surface of said body.

2. The augmented ground effect platform of claim **1**, wherein said air drive means includes a power means and a rotating propeller driven by said power means.

3. The augmented ground effect platform of claim **2**, wherein a plurality of antitorque vanes are mounted about the periphery of said body and angled with respect to the airflow over the exterior of said body to impart momentum to said body in a direction opposite the direction of rotation of said propeller.

4. The augmented ground effect platform of claim **1**, wherein control vanes are positioned at said first air cushion nozzles.

5. The augmented ground effect platform of claim **4**, wherein said control vanes are adjustable.

6. The augmented ground effect platform of claim **1**, wherein closure means are provided for closing said air intake cavity whereby the entire jet flow from said air drive means is diverted over said body.

7. The augmented ground effect platform of claim **1**, wherein airflow control means are provided about the upper surface of said body for assisting in said airflow following the downwardly radially curved exterior peripheral surface of said body.

8. The augmented ground effect platform of claim **1**, wherein airflow disruption means are provided about the upper surface of said body for selectively disrupting the airflow at selected positions about said body.

9. The augmented ground effect platform of claim **1**, further comprising reverse thruster means for controlling pitch and roll.

10. The augmented ground effect platform of claim **1** wherein said platform is connected to a second platform and serves as a lifting and landing platform.

11. The augmented ground effect platform of claim **10**, wherein the power for said air drive means is derived from said second platform.

12. An augmented ground effect platform comprising:

a substantially circular body formed with a downwardly radially curved exterior peripheral surface;

a downwardly facing lifting surface formed on the underside of said body;

a peripheral restoring surface extending around said lifting surface and angling upwardly and outwardly with respect thereto;

an air intake cavity formed in the upper surface of said body;

concentric annular nozzle means, including a first air curtain nozzle, a first air cushion nozzle, a second air curtain nozzle and a second air cushion nozzle;

first air passageway means connecting said intake cavity with said first air curtain nozzle, first air cushion nozzle and second air curtain nozzle;

second air passageway means connecting said intake cavity with said second air cushion nozzle;

an air drive means, said air drive means being positioned exterior of said body for directing a jet flow into said air intake cavity and also over the curved exterior peripheral surface of said body;

closure means for closing said air intake cavity whereby the entire jet flow from said air drive means is diverted over said body; and

airflow disruption means are provided about the upper surface of said body for selectively disrupting the airflow at selected positions about said body.

13

13. An augmented ground effect platform comprising:
a substantially circular body formed with a downwardly
radially curved exterior peripheral surface;
a downwardly facing lifting surface formed on the under-
side of said body; 5
a peripheral restoring surface extending around said lift-
ing surface and angling upwardly and outwardly with
respect thereto;
an air intake cavity formed in the upper surface of said 10
body;
concentric annular nozzle means, including a first air
curtain nozzle, a first air cushion nozzle, a second air
curtain nozzle and a second air cushion nozzle;

14

first air passageway means connecting said intake cavity
with said first air curtain nozzle, first air cushion nozzle
and second air curtain nozzle;
second air passageway means connecting said intake
cavity with said second air cushion nozzle;
an air drive means, said air drive means being positioned
exterior of said body for directing a jet flow into said air
intake cavity and also over the curved exterior periph-
eral surface of said body; and
wherein said platform is connected to a second platform
and serves as a lifting and landing platform and the
power for said air drive means is derived from said
second platform.

* * * * *